

## Handwheels with safety grip

### Item description/product images



### Description

#### Material:

Black grey thermoplastic.

#### Version:

Steel parts black oxidised.

#### Note:

The hub cover is supplied loose. The handwheels can be secured using a transverse pin or by parallel key connection together with a DIN 6912 socket head screw and a DIN 7349 washer.

Two steps have to be carried out to bring the cylindrical safety grip into operating position:

- Swivel the grip around the axis of rotation until it stops (90°).
- Push grip in axial position into locking position.

The pressed-in position is the most comfortable position to crank. When released, the grip automatically returns to original position.

Versions with transverse bore are secured using the ISO 4027 (DIN 914) grub screw. For assembly examples, see K0256.

### Drawings

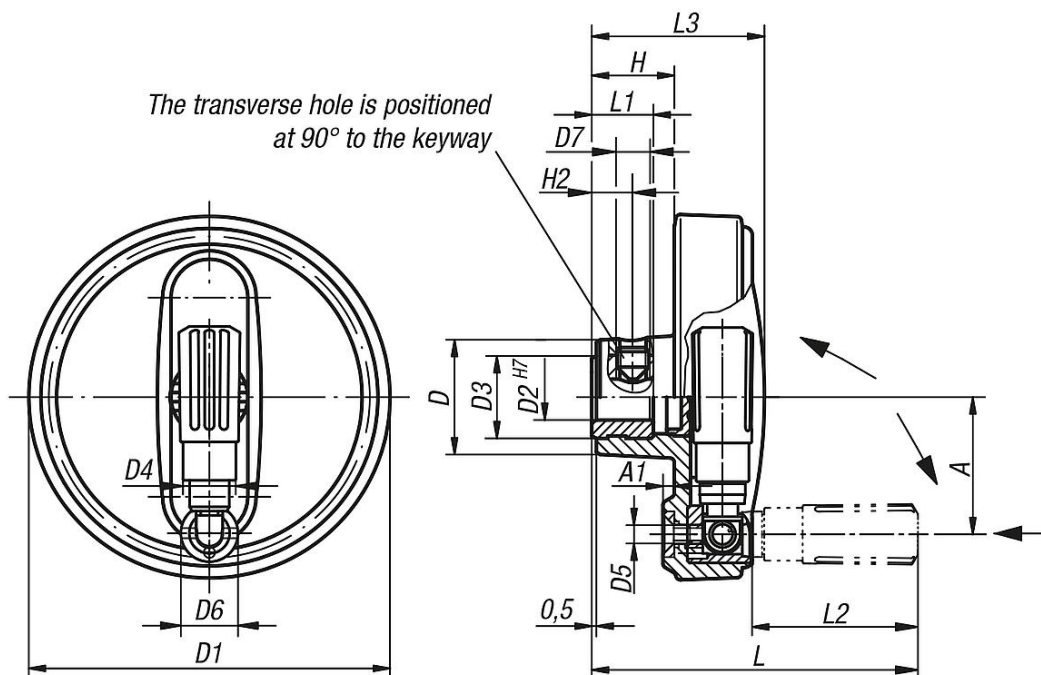

# Handwheels with safety grip

## Drawings

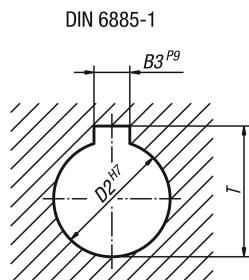

## Overview of items

### Handwheels with safety cylinder grip

Order No.	Version	Version 2	D	D1	D2	D3	D4	D5	D6	D7	A	A1	H	H2	L	L1	L2	L3	B3	T
K0259.108008	reamed hole	-	25	80	8H7	19	14	M4	13	-	30	2,5	17,6	-	72,6	13	38	36,7	-	-
K0259.108010	reamed hole	-	25	80	10H7	19	14	M4	13	-	30	2,5	17,6	-	72,6	13	38	36,7	-	-
K0259.108012	reamed hole	-	25	80	12H7	19	14	M4	13	-	30	2,5	17,6	-	72,6	13	38	36,7	-	-
K0259.210010	reamed hole	-	28	100	10H7	19	16	M5	16	-	38	3	20,1	-	88,6	13	47,5	43,5	-	-
K0259.210012	reamed hole	-	28	100	12H7	19	16	M5	16	-	38	3	20,1	-	88,6	13	47,5	43,5	-	-
K0259.312512	reamed hole	-	35	125	12H7	25	20	M6	20	-	47,5	4	23,3	-	107,7	18,5	58,4	52,1	-	-
K0259.312514	reamed hole	-	35	125	14H7	25	20	M6	20	-	47,5	4	23,3	-	107,7	18,5	58,4	52,1	-	-
K0259.312516	reamed hole	-	35	125	16H7	25	20	M6	20	-	47,5	4	23,3	-	107,7	18,5	58,4	52,1	-	-
K0259.416014	reamed hole	-	45	160	14H7	25	25	M8	26	-	62	5,6	28	-	142	18,5	81,6	63,8	-	-
K0259.416016	reamed hole	-	45	160	16H7	25	25	M8	26	-	62	5,6	28	-	142	18,5	81,6	63,8	-	-
K0259.10800802	reamed hole with slot	-	25	80	8H7	19	14	M4	13	-	30	2,5	17,6	-	72,6	13	38	36,7	2	9
K0259.10801003	reamed hole with slot	-	25	80	10H7	19	14	M4	13	-	30	2,5	17,6	-	72,6	13	38	36,7	3	11,4
K0259.10801204	reamed hole with slot	-	25	80	12H7	19	14	M4	13	-	30	2,5	17,6	-	72,6	13	38	36,7	4	13,8
K0259.21001003	reamed hole with slot	-	28	100	10H7	19	16	M5	16	-	38	3	20,1	-	88,6	13	47,5	43,5	3	11,4
K0259.21001204	reamed hole with slot	-	28	100	12H7	19	16	M5	16	-	38	3	20,1	-	88,6	13	47,5	43,5	4	13,8
K0259.31251204	reamed hole with slot	-	35	125	12H7	25	20	M6	20	-	47,5	4	23,3	-	107,7	18,5	58,4	52,1	4	13,8
K0259.31251405	reamed hole with slot	-	35	125	14H7	25	20	M6	20	-	47,5	4	23,3	-	107,7	18,5	58,4	52,1	5	16,3
K0259.31251605	reamed hole with slot	-	35	125	16H7	25	20	M6	20	-	47,5	4	23,3	-	107,7	18,5	58,4	52,1	5	18,3
K0259.41601405	reamed hole with slot	-	45	160	14H7	25	25	M8	26	-	62	5,6	28	-	142	18,5	81,6	63,8	5	16,3
K0259.41601605	reamed hole with slot	-	45	160	16H7	25	25	M8	26	-	62	5,6	28	-	142	18,5	81,6	63,8	5	18,3
K0259.1080086	reamed hole	with transverse bore	25	80	8H7	19	14	M4	13	M6	30	2,5	17,6	7,5	72,6	13	38	36,7	-	-
K0259.1080106	reamed hole	with transverse bore	25	80	10H7	19	14	M4	13	M6	30	2,5	17,6	7,5	72,6	13	38	36,7	-	-
K0259.1080126	reamed hole	with transverse bore	25	80	12H7	19	14	M4	13	M6	30	2,5	17,6	7,5	72,6	13	38	36,7	-	-
K0259.2100106	reamed hole	with transverse bore	28	100	10H7	19	16	M5	16	M6	38	3	20,1	7,5	88,6	13	47,5	43,5	-	-
K0259.2100126	reamed hole	with transverse bore	28	100	12H7	19	16	M5	16	M6	38	3	20,1	7,5	88,6	13	47,5	43,5	-	-
K0259.3125126	reamed hole	with transverse bore	35	125	12H7	25	20	M6	20	M6	47,5	4	23,3	7,5	107,7	18,5	58,4	52,1	-	-
K0259.3125146	reamed hole	with transverse bore	35	125	14H7	25	20	M6	20	M6	47,5	4	23,3	7,5	107,7	18,5	58,4	52,1	-	-
K0259.3125166	reamed hole	with transverse bore	35	125	16H7	25	20	M6	20	M6	47,5	4	23,3	7,5	107,7	18,5	58,4	52,1	-	-
K0259.4160146	reamed hole	with transverse bore	45	160	14H7	25	25	M8	26	M6	62	5,6	28	7,5	142	18,5	81,6	63,8	-	-
K0259.4160166	reamed hole	with transverse bore	45	160	16H7	25	25	M8	26	M6	62	5,6	28	7,5	142	18,5	81,6	63,8	-	-
K0259.108008026	reamed hole with slot	with transverse bore	25	80	8H7	19	14	M4	13	M6	30	2,5	17,6	7,5	72,6	13	38	36,7	2	9
K0259.108010036	reamed hole with slot	with transverse bore	25	80	10H7	19	14	M4	13	M6	30	2,5	17,6	7,5	72,6	13	38	36,7	3	11,4
K0259.108012046	reamed hole with slot	with transverse bore	25	80	12H7	19	14	M4	13	M6	30	2,5	17,6	7,5	72,6	13	38	36,7	4	13,8
K0259.210010036	reamed hole with slot	with transverse bore	28	100	10H7	19	16	M5	16	M6	38	3	20,1	7,5	88,6	13	47,5	43,5	3	11,4
K0259.210012046	reamed hole with slot	with transverse bore	28	100	12H7	19	16	M5	16	M6	38	3	20,1	7,5	88,6	13	47,5	43,5	4	13,8
K0259.312512046	reamed hole with slot	with transverse bore	35	125	12H7	25	20	M6	20	M6	47,5	4	23,3	7,5	107,7	18,5	58,4	52,1	4	13,8
K0259.312514056	reamed hole with slot	with transverse bore	35	125	14H7	25	20	M6	20	M6	47,5	4	23,3	7,5	107,7	18,5	58,4	52,1	5	16,3
K0259.312516056	reamed hole with slot	with transverse bore	35	125	16H7	25	20	M6	20	M6	47,5	4	23,3	7,5	107,7	18,5	58,4	52,1	5	18,3
K0259.416014056	reamed hole with slot	with transverse bore	45	160	14H7	25	25	M8	26	M6	62	5,6	28	7,5	142	18,5	81,6	63,8	5	16,3
K0259.416016056	reamed hole with slot	with transverse bore	45	160	16H7	25	25	M8	26	M6	62	5,6	28	7,5	142	18,5	81,6	63,8	5	18,3

