

Disc handwheels, aluminium, without grip, Form C with reamed hole and keyway

Item description/product images



Description

Material:

Handwheel aluminium.

Hub cover black thermoplastic.

ISO 4027 grub screw, steel grade 45 H, black.

Version:

Black or silver powder-coated.

Note:

Wheel rim radial and axial run-out ≤ 0.4 mm.

Assembly:

The hub cover is supplied unassembled.

The handwheels can be secured to a shaft using a transverse pin or by parallel key connection together with a DIN 6912 cap screw and a handwheel washer K0173.

By the versions with transverse bore, fixation is carried out using an ISO 4027 grub screw.

Supplied with:

Aluminium handwheel.

Hub cover.

ISO 4027 grub screw (type with transverse bore).

Accessory:

K0173 Handwheel washers.

K1160 Socket head screws with low head DIN 6912.

Drawing reference:

1) Position of the transverse bore to the keyway is offset by 90°.

Disc handwheels, aluminium, without grip, Form C with reamed hole and keyway

Item description/product images

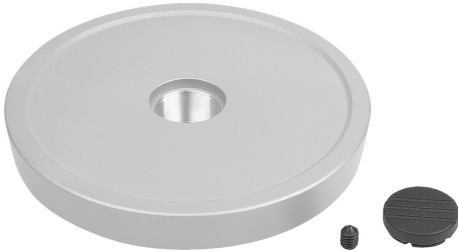
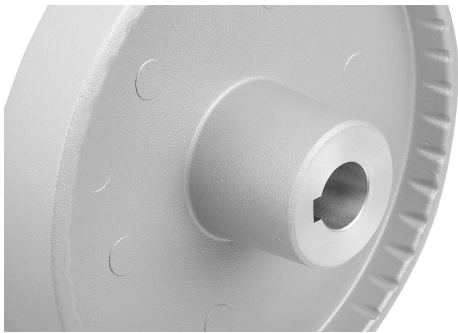
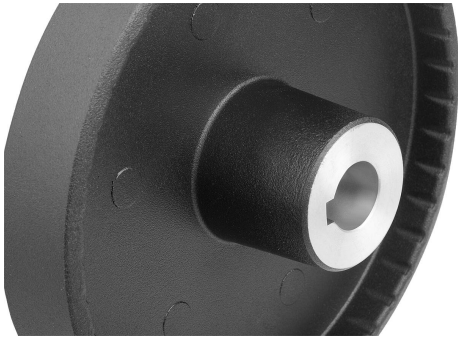

Disc handwheels, aluminium, without grip, Form C with reamed hole and keyway

Drawings

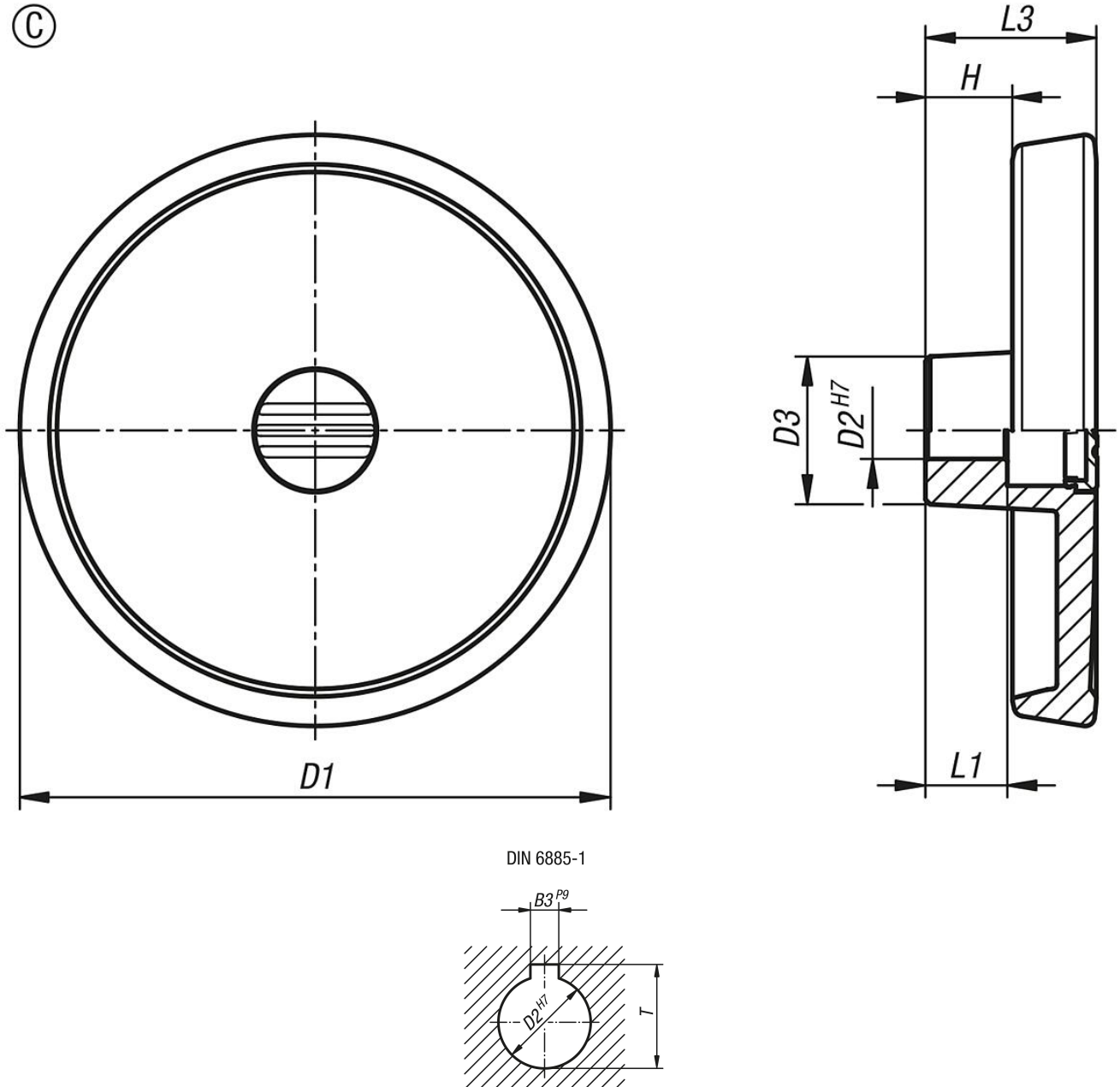

Overview of items

Order No.	Main colour	Form	Form definition	D1	D2	D3	L1	L3	H	B3	T
K1520.08010103	black	C	reamed hole with slot	80	10	26	16	29	16,6	3	11,4
K1520.08012104	black	C	reamed hole with slot	80	12	26	16	29	16,6	4	13,8
K1520.10010103	black	C	reamed hole with slot	100	10	28	17	33	17,5	3	11,4
K1520.10012104	black	C	reamed hole with slot	100	12	28	17	33	17,5	4	13,8
K1520.12512104	black	C	reamed hole with slot	125	12	31	18	36	18,3	4	13,8
K1520.12514105	black	C	reamed hole with slot	125	14	31	18	36	18,3	5	16,3
K1520.08010203	silver	C	reamed hole with slot	80	10	26	16	29	16,6	3	11,4
K1520.08012204	silver	C	reamed hole with slot	80	12	26	16	29	16,6	4	13,8
K1520.10010203	silver	C	reamed hole with slot	100	10	28	17	33	17,5	3	11,4
K1520.10012204	silver	C	reamed hole with slot	100	12	28	17	33	17,5	4	13,8
K1520.12512204	silver	C	reamed hole with slot	125	12	31	18	36	18,3	4	13,8

Disc handwheels, aluminium, without grip, Form C with reamed hole and keyway

Overview of items

Order No.	Main colour	Form	Form definition	D1	D2	D3	L1	L3	H	B3	T
K1520.12514205	silver	C	reamed hole with slot	125	14	31	18	36	18,3	5	16,3