

Disc handwheels, aluminium, without grip, Form B with reamed hole, keyway and transverse bore

Item description/product images



Description

Material:

Handwheel aluminium.

Hub cover black thermoplastic.

ISO 4027 grub screw, steel grade 45 H, black.

Version:

Black or silver powder-coated.

Note:

Wheel rim radial and axial run-out ≤ 0.4 mm.

Assembly:

The hub cover is supplied unassembled.

The handwheels can be secured to a shaft using a transverse pin or by parallel key connection together with a DIN 6912 cap screw and a handwheel washer K0173.

By the versions with transverse bore, fixation is carried out using an ISO 4027 grub screw.

Supplied with:

Aluminium handwheel.

Hub cover.

ISO 4027 grub screw (type with transverse bore).

Accessory:

K0173 Handwheel washers.

K1160 Socket head screws with low head DIN 6912.

Drawing reference:

1) Position of the transverse bore to the keyway is offset by 90° .

**Disc handwheels, aluminium, without grip, Form B with reamed hole,
keyway and transverse bore**

Item description/product images

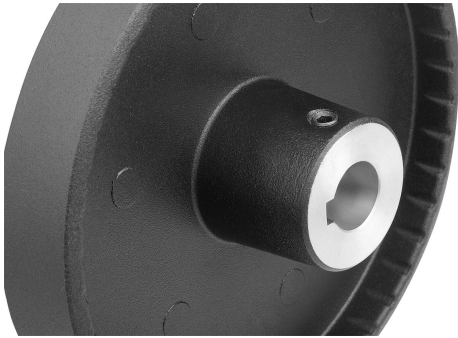

Disc handwheels, aluminium, without grip, Form B with reamed hole, keyway and transverse bore

Drawings

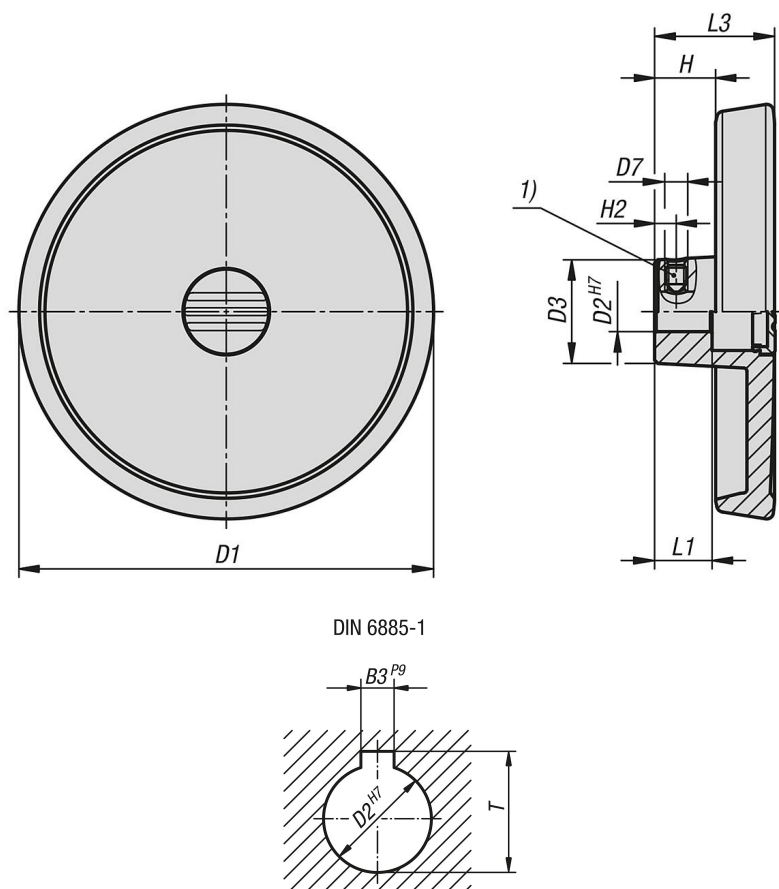

Overview of items

Order No.	Main colour	Form	Form definition	D1	D2	D3	L1	L3	H	H2	D7	B3	T
K1520.080101036	black	B	Reamed hole with slot, with transverse bore	80	10	26	16	29	16,6	5,5	M6	3	11,4
K1520.080121046	black	B	Reamed hole with slot, with transverse bore	80	12	26	16	29	16,6	6,5	M6	4	13,8
K1520.100101036	black	B	Reamed hole with slot, with transverse bore	100	10	28	17	33	17,5	5,5	M6	3	11,4
K1520.100121046	black	B	Reamed hole with slot, with transverse bore	100	12	28	17	33	17,5	6,5	M6	4	13,8
K1520.125121046	black	B	Reamed hole with slot, with transverse bore	125	12	31	18	36	18,3	6,5	M6	4	13,8
K1520.125141056	black	B	Reamed hole with slot, with transverse bore	125	14	31	18	36	18,3	6,5	M6	5	16,3
K1520.080102036	silver	B	Reamed hole with slot, with transverse bore	80	10	26	16	29	16,6	5,5	M6	3	11,4
K1520.080122046	silver	B	Reamed hole with slot, with transverse bore	80	12	26	16	29	16,6	6,5	M6	4	13,8
K1520.100102036	silver	B	Reamed hole with slot, with transverse bore	100	10	28	17	33	17,5	5,5	M6	3	11,4
K1520.100122046	silver	B	Reamed hole with slot, with transverse bore	100	12	28	17	33	17,5	6,5	M6	4	13,8
K1520.125122046	silver	B	Reamed hole with slot, with transverse bore	125	12	31	18	36	18,3	6,5	M6	4	13,8
K1520.125142056	silver	B	Reamed hole with slot, with transverse bore	125	14	31	18	36	18,3	6,5	M6	5	16,3