

Disc handwheels, aluminium, without grip, Form A with reamed hole and transverse bore

Item description/product images



Description

Material:

Handwheel aluminium.

Hub cover black thermoplastic.

ISO 4027 grub screw, steel grade 45 H, black.

Version:

Black or silver powder-coated.

Note:

Wheel rim radial and axial run-out ≤ 0.4 mm.

Assembly:

The hub cover is supplied unassembled.

The handwheels can be secured to a shaft using a transverse pin or by parallel key connection together with a DIN 6912 cap screw and a handwheel washer K0173.

By the versions with transverse bore, fixation is carried out using an ISO 4027 grub screw.

Supplied with:

Aluminium handwheel.

Hub cover.

ISO 4027 grub screw (type with transverse bore).

Accessory:

K0173 Handwheel washers.

K1160 Socket head screws with low head DIN 6912.

Drawing reference:

1) Position of the transverse bore to the keyway is offset by 90° .

Disc handwheels, aluminium, without grip, Form A with reamed hole and transverse bore

Item description/product images

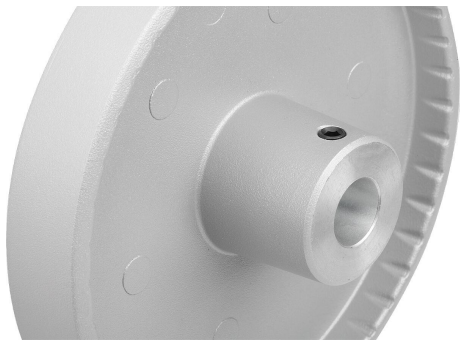
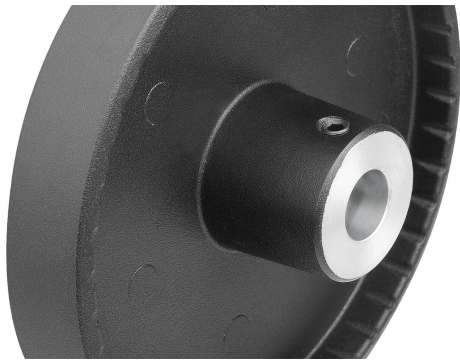

Disc handwheels, aluminium, without grip, Form A with reamed hole and transverse bore

Drawings

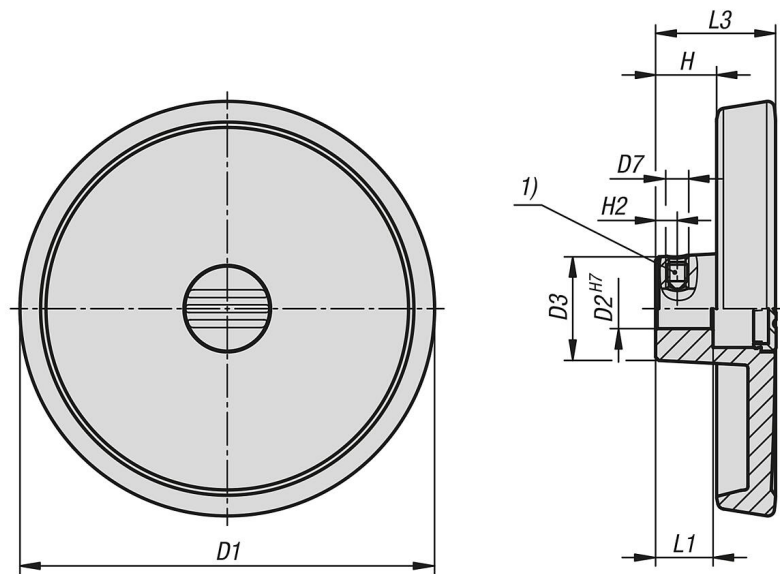

Overview of items

Order No.	Main colour	Form	Form definition	D1	D2	D3	L1	L3	H	H2	D7
K1520.0801016	black	A	reamed hole with tranverse bore	80	10	26	16	29	16,6	5,5	M6
K1520.0801216	black	A	reamed hole with tranverse bore	80	12	26	16	29	16,6	6,5	M6
K1520.1001016	black	A	reamed hole with tranverse bore	100	10	28	17	33	17,5	5,5	M6
K1520.1001216	black	A	reamed hole with tranverse bore	100	12	28	17	33	17,5	6,5	M6
K1520.1251216	black	A	reamed hole with tranverse bore	125	12	31	18	36	18,3	6,5	M6
K1520.1251416	black	A	reamed hole with tranverse bore	125	14	31	18	36	18,3	6,5	M6
K1520.0801026	silver	A	reamed hole with tranverse bore	80	10	26	16	29	16,6	5,5	M6
K1520.0801226	silver	A	reamed hole with tranverse bore	80	12	26	16	29	16,6	6,5	M6
K1520.1001026	silver	A	reamed hole with tranverse bore	100	10	28	17	33	17,5	5,5	M6
K1520.1001226	silver	A	reamed hole with tranverse bore	100	12	28	17	33	17,5	6,5	M6
K1520.1251226	silver	A	reamed hole with tranverse bore	125	12	31	18	36	18,3	6,5	M6
K1520.1251426	silver	A	reamed hole with tranverse bore	125	14	31	18	36	18,3	6,5	M6