

2-spoke handwheels, aluminium, with revolving cylinder grip, Form C with reamed hole and keyway

Item description/product images



Description

Material:

Handwheel aluminium.
Cylinder grip and hub cover black thermoplastic.
Cylinder grip pin black oxidised steel.
ISO 4027 grub screw, steel grade 45 H, black.

Version:

Black or silver powder-coated.

Note:

Wheel rim radial and axial run-out ≤ 0.4 mm.

Assembly:

The hub cover and the revolving cylinder grip are supplied unassembled. To assemble, screw the grip into the tapped hole.
The handwheels can be secured to a shaft using a transverse pin or by parallel key connection together with a DIN 6912 cap screw and a handwheel washer K0173.
By the versions with transverse bore, fixation is carried out using an ISO 4027 grub screw.

Supplied with:

Aluminium handwheel.
Hub cover.
Revolving cylinder grip.
ISO 4027 grub screw (type with transverse bore).

Accessory:

K0173 Handwheel washers.
K1160 Socket head screws with low head DIN 6912.

Drawing reference:

1) Position of the transverse bore to the keyway is offset by 90° .

2-spoke handwheels, aluminium, with revolving cylinder grip, Form C with reamed hole and keyway

Item description/product images



Drawings

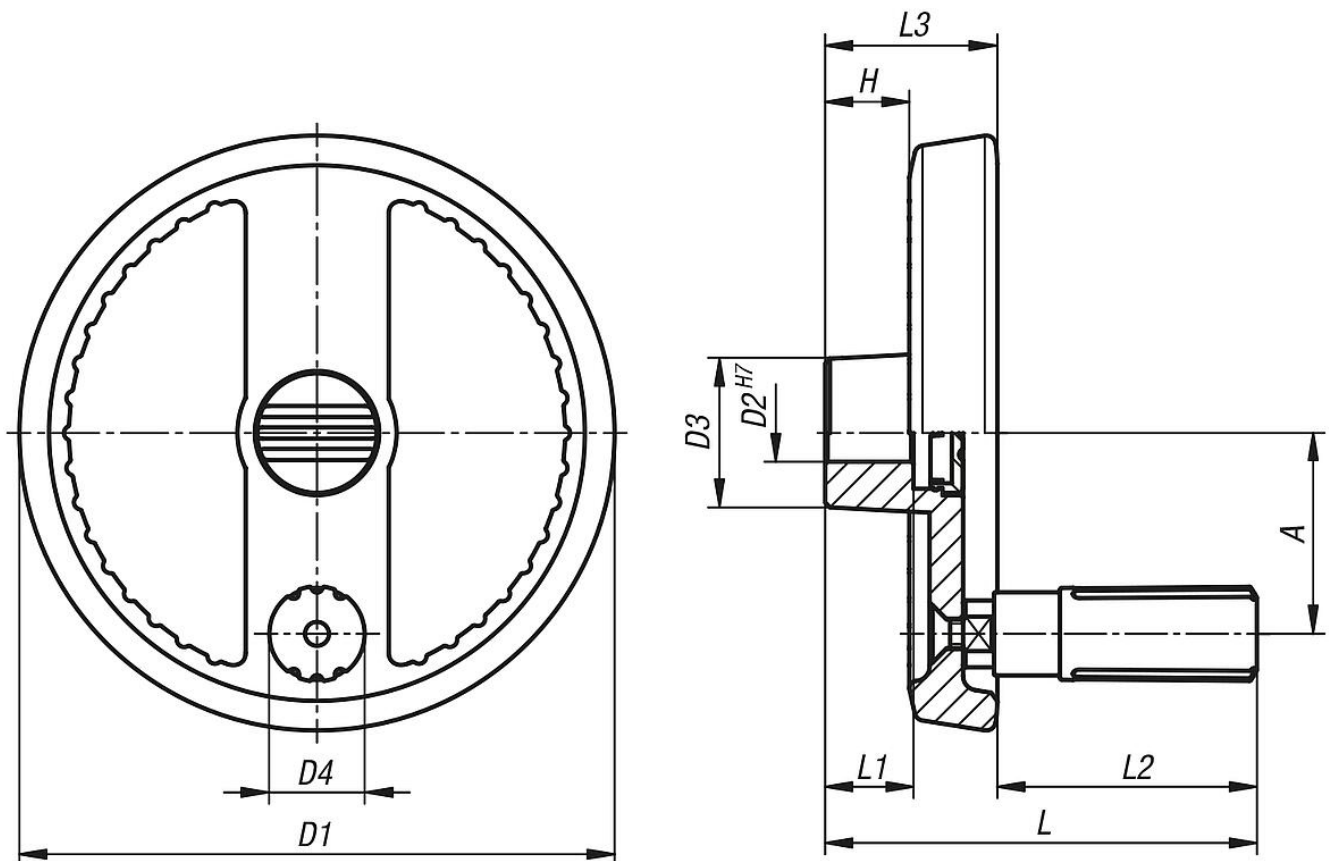

2-spoke handwheels, aluminium, with revolving cylinder grip, Form C with reamed hole and keyway

Drawings

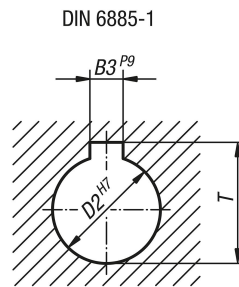

Overview of items

Order No.	Main colour	Form	Form definition	A	B3	D1	D2	D3	D4	D5	H	L	L1	L2	L3	T
K1524.12512104	black	C	reamed hole with slot	42	4	125	12	31	19,9	M6	17,6	90,5	18	54,5	36	13,8
K1524.12514105	black	C	reamed hole with slot	42	5	125	14	31	19,9	M6	17,6	90,5	18	54,5	36	16,3
K1524.16014105	black	C	reamed hole with slot	55	5	160	14	36	25,2	M8	19,4	116,5	20	76,5	40	16,3
K1524.16016105	black	C	reamed hole with slot	55	5	160	16	36	25,2	M8	19,4	116,5	20	76,5	40	18,3
K1524.12512204	silver	C	reamed hole with slot	42	4	125	12	31	19,9	M6	17,6	90,5	18	54,5	36	13,8
K1524.12514205	silver	C	reamed hole with slot	42	5	125	14	31	19,9	M6	17,6	90,5	18	54,5	36	16,3
K1524.16014205	silver	C	reamed hole with slot	55	5	160	14	36	25,2	M8	19,4	116,5	20	76,5	40	16,3
K1524.16016205	silver	C	reamed hole with slot	55	5	160	16	36	25,2	M8	19,4	116,5	20	76,5	40	18,3