

Disc handwheels, aluminium with revolving cylindrical grip, Form B with reamed hole, keyway and transverse bore

Item description/product images



Description

Material:

Handwheel aluminium.

Cylinder grip and hub cover black thermoplastic.

Cylinder grip pin black oxidised steel.

ISO 4027 grub screw, steel grade 45 H, black.

Version:

Black or silver powder-coated.

Note:

Wheel rim radial and axial run-out ≤ 0.4 mm.

Assembly:

The hub cover and the revolving cylinder grip are supplied unassembled. To assemble, screw the grip into the tapped hole.

The handwheels can be secured to a shaft using a transverse pin or by parallel key connection together with a DIN 6912 cap screw and a handwheel washer K0173.

By the versions with transverse bore, fixation is carried out using an ISO 4027 grub screw.

Supplied with:

Aluminium handwheel.

Hub cover.

Revolving cylinder grip.

ISO 4027 grub screw (type with transverse bore).

Accessory:

K0173 Handwheel washers.

K1160 Socket head screws with low head DIN 6912.

Drawing reference:

1) Position of the transverse bore to the keyway is offset by 90° .

Disc handwheels, aluminium with revolving cylindrical grip, Form B with reamed hole, keyway and transverse bore

Item description/product images



Drawings

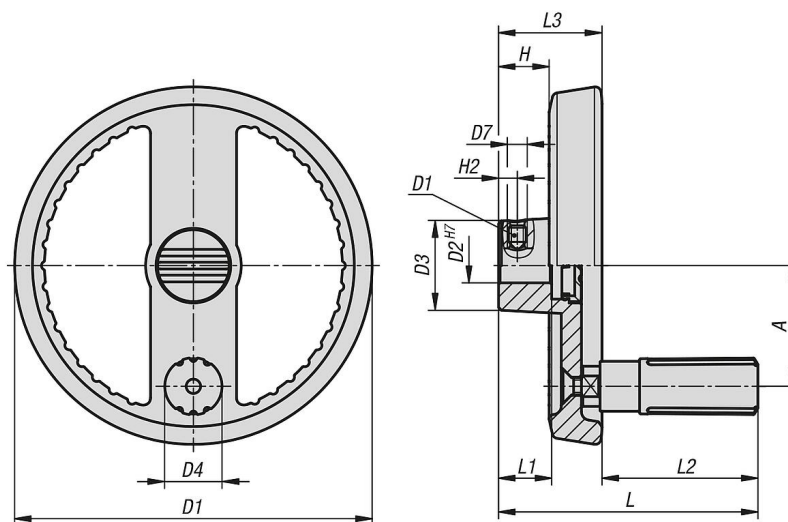

DIN 6885-1

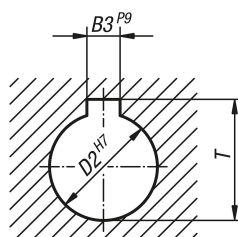

Disc handwheels, aluminium with revolving cylindrical grip, Form B with reamed hole, keyway and transverse bore

Overview of items

Order No.	Main colour	Form	Form definition	A	B3	D1	D2	D3	D4	D5	D7	H	H2	L	L1	L2	L3	T
K1524.125121046	black	B	reamed hole with slot, with transverse bore	42	4	125	12	31	19,9	M6	M6	17,6	6,5	90,5	18	54,5	36	13,8
K1524.125141056	black	B	reamed hole with slot, with transverse bore	42	5	125	14	31	19,9	M6	M6	17,6	6,5	90,5	18	54,5	36	16,3
K1524.160141056	black	B	reamed hole with slot, with transverse bore	55	5	160	14	36	25,2	M8	M6	19,4	6,5	116,5	20	76,5	40	16,3
K1524.160161056	black	B	reamed hole with slot, with transverse bore	55	5	160	16	36	25,2	M8	M6	19,4	8	116,5	20	76,5	40	18,3
K1524.125122046	silver	B	reamed hole with slot, with transverse bore	42	4	125	12	31	19,9	M6	M6	17,6	6,5	90,5	18	54,5	36	13,8
K1524.125142056	silver	B	reamed hole with slot, with transverse bore	42	5	125	14	31	19,9	M6	M6	17,6	6,5	90,5	18	54,5	36	16,3
K1524.160142056	silver	B	reamed hole with slot, with transverse bore	55	5	160	14	36	25,2	M8	M6	19,4	6,5	116,5	20	76,5	40	16,3
K1524.160162056	silver	B	reamed hole with slot, with transverse bore	55	5	160	16	36	25,2	M8	M6	19,4	8	116,5	20	76,5	40	18,3