

Handwheels DIN 950 grey cast iron, with fixed grip

Item description/product images



Description

Material:
Handwheel grey cast iron

Version:
Wheel rim turned and polished.

On request:
Hubs with square socket or powder-coated handwheels.

Drawings

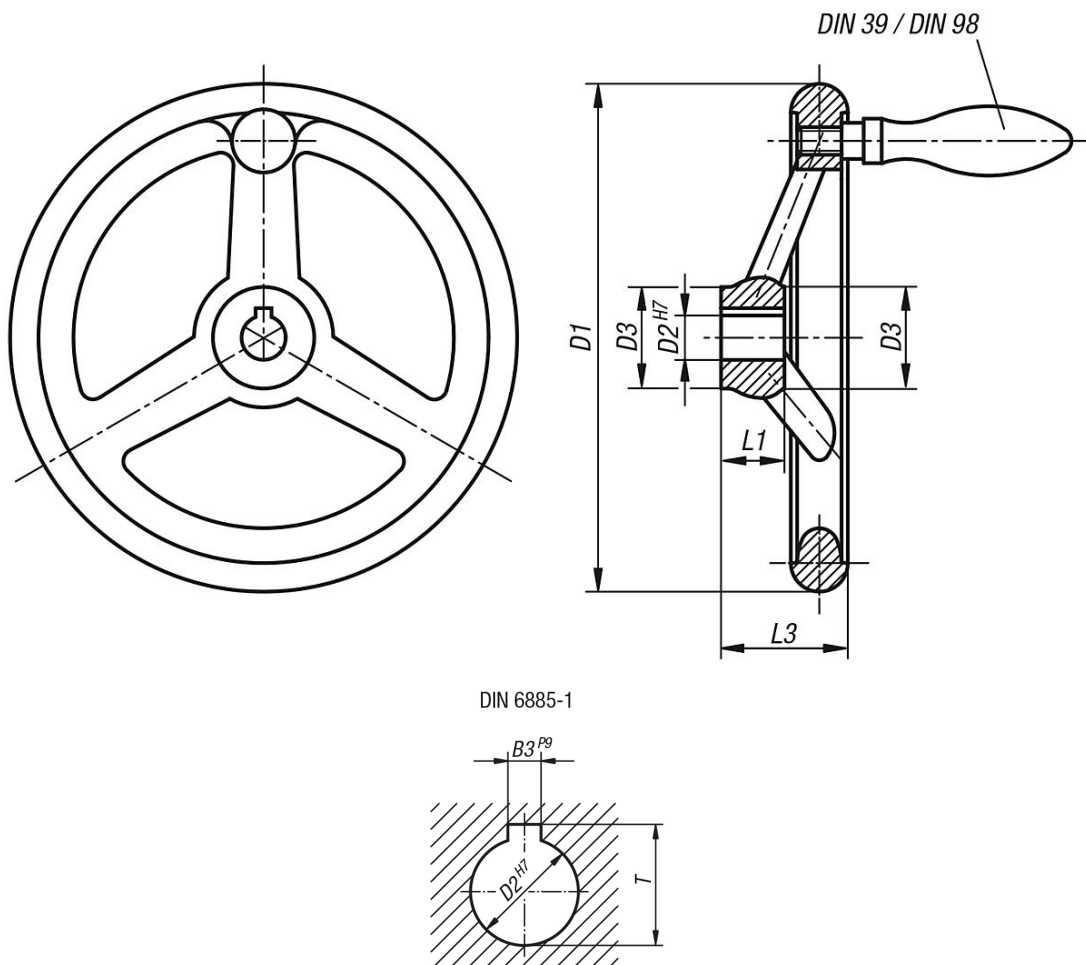

Handwheels DIN 950 grey cast iron, with fixed grip

Overview of items

Order No.	Version 1	D1	D2	D3	L1	L3	B3	T	Number of spokes	fixed machine handle DIN 39 Form E
K0671.2080X10	reamed hole	80	10H7	25	16	29	-	-	3	ø16 x M6 x 50
K0671.2080X12	reamed hole	80	12H7	25	16	29	-	-	3	ø16 x M6 x 50
K0671.2100X10	reamed hole	100	10H7	26	17	33	-	-	3	ø16 x M6 x 50
K0671.2100X12	reamed hole	100	12H7	26	17	33	-	-	3	ø16 x M6 x 50
K0671.2125X12	reamed hole	125	12H7	33	18	36	-	-	3	ø20 x M8 x 64
K0671.2125X14	reamed hole	125	14H7	33	18	36	-	-	3	ø20 x M8 x 64
K0671.2140X14	reamed hole	140	14H7	33	19	39	-	-	3	ø20 x M8 x 64
K0671.2140X16	reamed hole	140	16H7	33	19	39	-	-	3	ø20 x M8 x 64
K0671.2160X14	reamed hole	160	14H7	37	20	40	-	-	3	ø25 x M10 x 80
K0671.2160X16	reamed hole	160	16H7	37	20	40	-	-	3	ø25 x M10 x 80
K0671.2180X16	reamed hole	180	16H7	36	22	43	-	-	3	ø25 x M10 x 80
K0671.2180X18	reamed hole	180	18H7	36	22	43	-	-	3	ø25 x M10 x 80
K0671.2200X18	reamed hole	200	18H7	38	24	45	-	-	3	ø25 x M10 x 80
K0671.2200X22	reamed hole	200	22H7	38	24	45	-	-	3	ø25 x M10 x 80
K0671.2250X22	reamed hole	250	22H7	46	28	50	-	-	5	ø32 x M12 x 100
K0671.2250X26	reamed hole	250	26H7	46	28	50	-	-	5	ø32 x M12 x 100
K0671.2315X26	reamed hole	315	26H7	54	33	56	-	-	5	ø32 x M12 x 100
K0671.2315X30	reamed hole	315	30H7	54	33	56	-	-	5	ø32 x M12 x 100
K0671.2400X30	reamed hole	400	30H7	68	38	63	-	-	5	ø36 x M16 x 112
K0671.2400X34	reamed hole	400	34H7	68	38	63	-	-	5	ø36 x M16 x 112
K0671.2500X34	reamed hole	500	34H7	79	45	72	-	-	5	ø36 x M16 x 112
K0671.2500X40	reamed hole	500	40H7	79	45	72	-	-	5	ø36 x M16 x 112
K0671.3080X10	reamed hole with slot	80	10H7	25	16	29	3	11,4	3	ø16 x M6 x 50
K0671.3080X12	reamed hole with slot	80	12H7	25	16	29	4	13,8	3	ø16 x M6 x 50
K0671.3100X10	reamed hole with slot	100	10H7	26	17	33	3	11,4	3	ø16 x M6 x 50
K0671.3100X12	reamed hole with slot	100	12H7	26	17	33	4	13,8	3	ø16 x M6 x 50
K0671.3125X12	reamed hole with slot	125	12H7	33	18	36	4	13,8	3	ø20 x M8 x 64
K0671.3125X14	reamed hole with slot	125	14H7	33	18	36	5	16,3	3	ø20 x M8 x 64
K0671.3140X14	reamed hole with slot	140	14H7	33	19	39	5	16,3	3	ø20 x M8 x 64
K0671.3140X16	reamed hole with slot	140	16H7	33	19	39	5	18,3	3	ø20 x M8 x 64
K0671.3160X14	reamed hole with slot	160	14H7	37	20	40	5	16,3	3	ø25 x M10 x 80
K0671.3160X16	reamed hole with slot	160	16H7	37	20	40	5	18,3	3	ø25 x M10 x 80
K0671.3180X16	reamed hole with slot	180	16H7	36	22	43	5	18,3	3	ø25 x M10 x 80
K0671.3180X18	reamed hole with slot	180	18H7	36	22	43	6	20,8	3	ø25 x M10 x 80
K0671.3200X18	reamed hole with slot	200	18H7	38	24	45	6	20,8	3	ø25 x M10 x 80
K0671.3200X22	reamed hole with slot	200	22H7	38	24	45	6	24,8	3	ø25 x M10 x 80
K0671.3250X22	reamed hole with slot	250	22H7	46	28	50	6	24,8	5	ø32 x M12 x 100
K0671.3250X26	reamed hole with slot	250	26H7	46	28	50	8	29,3	5	ø32 x M12 x 100
K0671.3315X26	reamed hole with slot	315	26H7	54	33	56	8	29,3	5	ø32 x M12 x 100
K0671.3315X30	reamed hole with slot	315	30H7	54	33	56	8	33,3	5	ø32 x M12 x 100
K0671.3400X30	reamed hole with slot	400	30H7	68	38	63	8	33,3	5	ø36 x M16 x 112
K0671.3400X34	reamed hole with slot	400	34H7	68	38	63	10	37,3	5	ø36 x M16 x 112
K0671.3500X34	reamed hole with slot	500	34H7	79	45	72	10	37,3	5	ø36 x M16 x 112
K0671.3500X40	reamed hole with slot	500	40H7	79	45	72	12	43,3	5	ø36 x M16 x 112