

## Plastic clamping lever with female thread and clamping force intensifier

### Item description/product images



### Description

#### Product description:

By using clamping levers with integrated clamping force intensifier, the clamping force can be increased by up to 75% compared to standard clamping levers.

Furthermore, this product can also be used by persons with limited hand strength (e.g. in rehabilitation) to achieve comparable clamping forces with less effort. Less effort is also needed to loosen the clamping lever.

The increase in clamping force is achieved by the integral needle roller thrust bearing, which generates very low surface friction on a rigid contact surface during clamping. The hardened thrust washers are designed for high clamping forces and the bearing with its high load rating guarantees a long service life.

The clamped component is permanently protected by the large, stationary contact surface. A washer is no longer required.

#### Material:

Handle fibreglass reinforced plastic with die-cast zinc toothed ring.  
Steel parts stainless steel 1.4305.

#### Version:

Steel parts bright.  
Axial needle bearing with hardened and ground thrust washer.

#### Type of operation:

The handle lever is engaged in the toothed insert by means of a toothed ring when not actuated, enabling the thread to be tightened or loosened. By lifting the handle, it can be repositioned and re-engaged in the toothed ring by spring force.

#### Application:

Machine, equipment and plant construction, rehabilitation sector.

#### Advantages:

Significant increase of the clamping force with the same tightening torque.  
High quality axial needle bearing with high load rating and long service life.  
The component surface is protected by the stationary lower ring

#### On request:

Other colours.

**Plastic clamping lever with female thread and clamping force intensifier**Item description/product images

---



**Plastic clamping lever with female thread and clamping force intensifier**Item description/product images

---



# Plastic clamping lever with female thread and clamping force intensifier

Item description/product images

---



lift to  
disengage



## Plastic clamping lever with female thread and clamping force intensifier

### Drawings

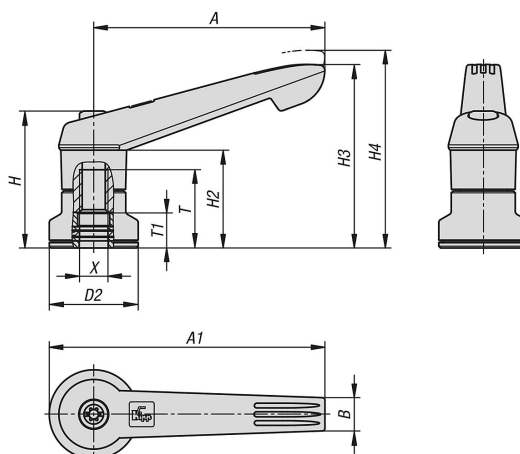

### Overview of items

#### Clamping levers, plastic with female thread and clamping force intensifier

Order No.	Main colour	X	D2	H	H2	H3	H4	A	A1	B	T	T1
K1598.2081	black grey RAL 7021	M8	25	38,5	27,5	51,6	55,6	65	77,5	9,4	22	10
K1598.3101	black grey RAL 7021	M10	30	47	34	63,4	67,9	80	95	11,1	24	10
K1598.4101	black grey RAL 7021	M10	30	53,1	36	71,1	76,1	95,4	110,4	13,2	27	10
K1598.5121	black grey RAL 7021	M12	35	59,1	43	82,8	87,8	109,9	127,4	15,6	33	10
K1598.2082	orange RAL 2004	M8	25	38,5	27,5	51,6	55,6	65	77,5	9,4	22	10
K1598.3102	orange RAL 2004	M10	30	47	34	63,4	67,9	80	95	11,1	24	10
K1598.4102	orange RAL 2004	M10	30	53,1	36	71,1	76,1	95,4	110,4	13,2	27	10
K1598.5122	orange RAL 2004	M12	35	59,1	43	82,8	87,8	109,9	127,4	15,6	33	10
K1598.20816	rape yellow RAL 1021	M8	25	38,5	27,5	51,6	55,6	65	77,5	9,4	22	10
K1598.31016	rape yellow RAL 1021	M10	30	47	34	63,4	67,9	80	95	11,1	24	10
K1598.41016	rape yellow RAL 1021	M10	30	53,1	36	71,1	76,1	95,4	110,4	13,2	27	10
K1598.51216	rape yellow RAL 1021	M12	35	59,1	43	82,8	87,8	109,9	127,4	15,6	33	10
K1598.20886	signal green RAL 6032	M8	25	38,5	27,5	51,6	55,6	65	77,5	9,4	22	10
K1598.31086	signal green RAL 6032	M10	30	47	34	63,4	67,9	80	95	11,1	24	10
K1598.41086	signal green RAL 6032	M10	30	53,1	36	71,1	76,1	95,4	110,4	13,2	27	10
K1598.51286	signal green RAL 6032	M12	35	59,1	43	82,8	87,8	109,9	127,4	15,6	33	10
K1598.20887	traffic blue RAL 5017	M8	25	38,5	27,5	51,6	55,6	65	77,5	9,4	22	10
K1598.31087	traffic blue RAL 5017	M10	30	47	34	63,4	67,9	80	95	11,1	24	10
K1598.41087	traffic blue RAL 5017	M10	30	53,1	36	71,1	76,1	95,4	110,4	13,2	27	10
K1598.51287	traffic blue RAL 5017	M12	35	59,1	43	82,8	87,8	109,9	127,4	15,6	33	10
K1598.20884	red RAL 3020	M8	25	38,5	27,5	51,6	55,6	65	77,5	9,4	22	10
K1598.31084	red RAL 3020	M10	30	47	34	63,4	67,9	80	95	11,1	24	10
K1598.41084	red RAL 3020	M10	30	53,1	36	71,1	76,1	95,4	110,4	13,2	27	10
K1598.51284	red RAL 3020	M12	35	59,1	43	82,8	87,8	109,9	127,4	15,6	33	10
K1598.20888	light grey RAL 7035	M8	25	38,5	27,5	51,6	55,6	65	77,5	9,4	22	10
K1598.31088	light grey RAL 7035	M10	30	47	34	63,4	67,9	80	95	11,1	24	10
K1598.41088	light grey RAL 7035	M10	30	53,1	36	71,1	76,1	95,4	110,4	13,2	27	10
K1598.51288	light grey RAL 7035	M12	35	59,1	43	82,8	87,8	109,9	127,4	15,6	33	10